

CPT1000-28S28-001 Rev A1 04272026**12–48 Vdc Input | 28 Vdc Output | MIL-STD Compliant**

1. Product Description

This is a high-power, rugged 1000 W DC-DC converter designed for demanding military, aerospace, and harsh-environment applications. The unit accepts a wide 12 Vdc to 48 Vdc input range and delivers a tightly regulated 28 Vdc output capable of supplying up to 36 A continuous output current.

The converter features a seamless linear transfer characteristic across the nominal output voltage range, ensuring stable and predictable operation during input voltage variations, including brownouts, surges, and transients commonly encountered in vehicle and airborne power systems.

Optimized for high efficiency, the converter minimizes power dissipation, allowing the use of a compact cooling plate and enabling high power density in weight- and space-constrained platforms.

2. Key Features

- **Wide Input Voltage Range:** 12 Vdc to 48 Vdc
- **High Power Output:** 28 Vdc, up to 1000 W (36 A)
- **High Efficiency Operation**
 - Enables reduced losses and a smaller cooling plate
- **MIL-STD-1275E Compliant**
 - Protection against input undervoltage, overvoltage, and transient disturbances
- **Reverse Input Voltage Protection**
 - Protects the unit against accidental polarity reversal
- **Overload and Short-Circuit Protection**
 - Automatic protection to ensure safe operation under fault conditions
- **Thermal Overload Shutdown**
 - Prevents overheating and protects the converter from thermal damage
- **Parallel Operation Capability**
 - Supports output power scaling for higher power systems
- **EMC Design**
 - Designed to meet conducted and radiated susceptibility requirements per **MIL-STD-461F**
- **Rugged Mechanical Design**
 - Qualified for vibration and shock per **MIL-STD-810**
- **Configurable Output Voltage**
 - Can be ordered with output levels in the range of **18 Vdc to 48 Vdc**

3. Typical Applications

- Military ground vehicles and armoured platforms
- Airborne and avionics systems
- Naval and marine electronics
- Radar, communications, and mission systems
- Unmanned systems (UGV / UAV)
- Rugged industrial and defence power architectures

4. System Benefits

Designed for the world's most demanding platforms, the 1000 W DC-DC Converter combines cutting-edge power density, wide input voltage tolerance, and full MIL-STD ruggedization to provide exceptionally efficient, stable, and dependable power under extreme electrical, mechanical, and environmental stress.

5. Compliance Summary

- **MIL-STD-1275E** – Vehicle power input characteristics
- **MIL-STD-461F** – Conducted and radiated susceptibility (design compliant)
- **MIL-STD-810** – Environmental (shock, vibration, temperature)

6. Electrical Specifications

Description	Value
Input	
Nominal Input Voltage	28v
Full Power Input range	12v ÷ 48v
Degraded output power (Limited time)	9v ÷ 12v (10Sec.)
Reverse Input Protection	Automatic recovery
Meet MIL-STD 1275E	
Design to Meet MIL-STD 461F*	Might need an external Filter
Output	
Output Voltage	28v
Output Power	1000w
Line Regulation	±0.2%
Load Regulation	±0.2%
Output ripple	50mVrms
Output Current limit, Short	Automatic recovery
Efficiency	97-99%
Environment	
Operating Temperature	-40 +75
Storage Temperature	-40 +95
Vibration - MIL-STD-810G	Method 514.5
Transportation - Trucks & Trailers	Cat. 4 & 5
Galvanic isolation	500Vdc, between Input/Output to case
Dimensions	168 X 117 X 30
Weight	550gr

*Compliance to limit CE 102 of MIL-STD 461 may require an external EMI filter

7. Use cases

The 9V to 48VDC input range is designed to enable the converter to work through the dips and surges commonly seen in vehicle and aircraft applications. A soft start process provides well-controlled outputs with no overshoot.

This versatile converter's wide operating temperature range, high efficiency, and comprehensive protection features (reverse polarity, under-voltage, over-voltage, and short circuit) make it a compelling choice for a variety of applications, including:

- Unmanned Ground Vehicles (UGV)
- Unmanned Aerial Vehicles (UAV)
- Loitering Munitions
- Mobile Communication
- Emergency Backup Systems
- Recreational Vehicle (RV) Automotive
- Marine Applications
- Rugged Environments

Experience dependable power delivery and adaptability for your mission-critical needs with our 1000W 28V DC-DC Converter.



9. Enclosure Drawing

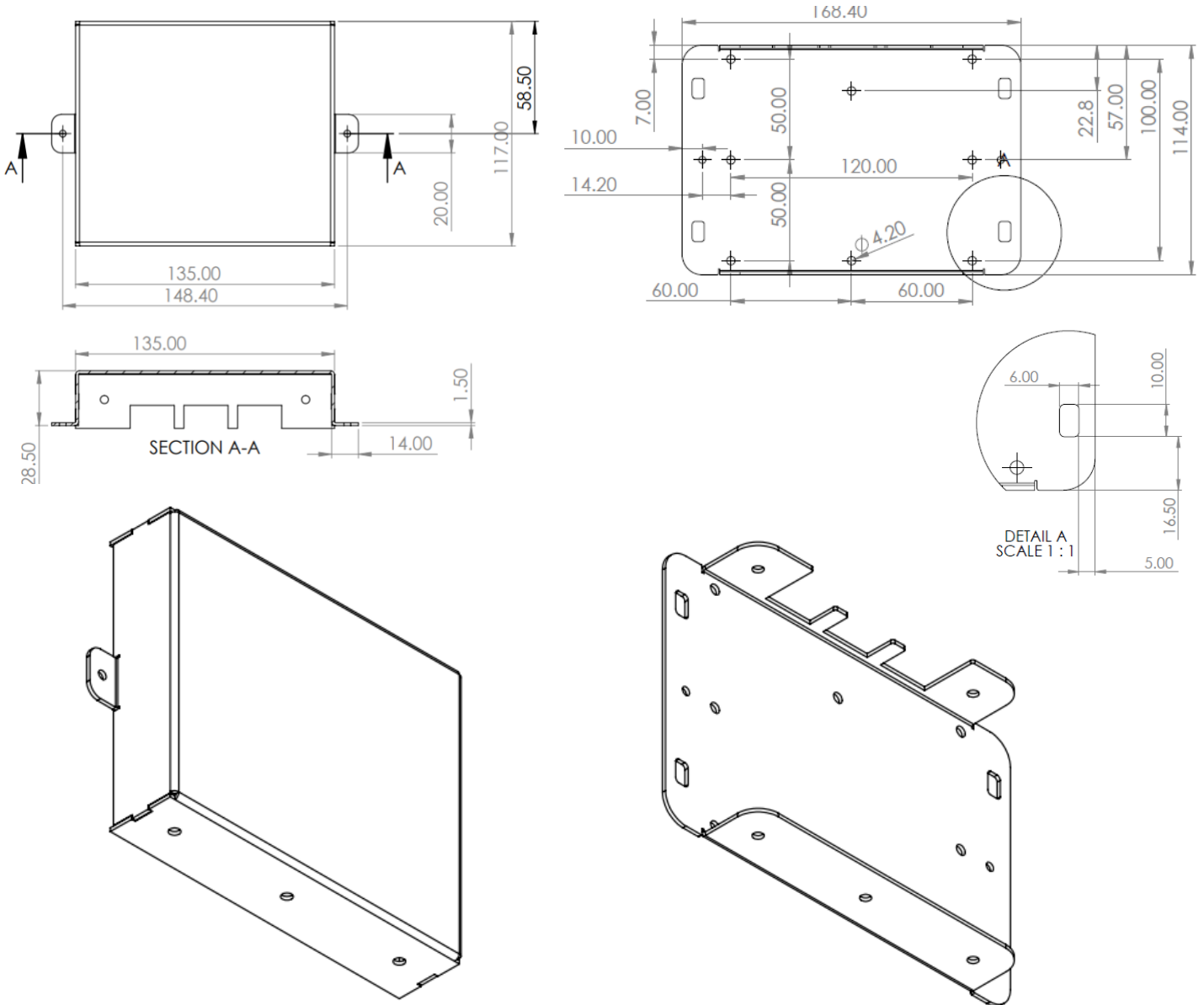

NOTES:

- 1. Warranty: 2 years.**
2. Specification is subject to change without notice.